

# **Montreal Protocol**



## **Process Agents Task Force**

### **Case Study #16**

**Preparation of perfluoropolyether diols with high functionality  
(difunctional molecules content  $\geq 99\%$ )**

**May 2001**

## **Notice**

The United Nations Environment Program (UNEP), the UNEP Process Agents Task Force chairs and members and the companies and organisations that employ UNEP Process Agents Task Force chairs and members do not endorse the performance, worker safety, or environmental acceptability of any of the technical options discussed. Every industrial operation requires consideration of worker safety and proper disposal of contaminants and waste products. Moreover, as work continues -- including additional toxicity testing and evaluation -- more information on health, environmental and safety effects of alternatives and replacements will become available for use in selecting among the options discussed in this document.

UNEP and the UNEP Process Agents Task Force chairs and members, in furnishing or distributing this information, do not make any warranty or representation, either express or implied, with respect to the accuracy, completeness, or utility; nor does UNEP or members and chairs of the UNEP Process Agents Task Force assume liability of any kind whatsoever resulting from the use, reliance upon, any information, material, or procedure contained herein, including but not limited to any claims regarding health, safety, environmental effects or fate, efficacy, or performance, made by the source of information.

Mention of any company, association, or product in this document is for information purposes only and does not constitute a recommendation of any such company, association, or product, either express or implied by UNEP, the UNEP Process Agents Task Force chairs or members and the companies or organisations that employ the UNEP Process Agents Task Force chairs and members.

**This Report of the  
Process Agents Task Force  
is available on the Internet  
in Portable Document Format (PDF)  
at:  
<http://www.teap.org>**

# CS-16

## Preparation of perfluoropolyether diols with high functionality (difunctional molecules content $\geq 99\%$ )

ODS type: CFC 113

### **Process description**

The process consists first in adsorbing the PFPE mixture, diluted in CFC 113/methanol, on a stationary phase, silica gel, capable of forming either polar interaction or hydrogen bonds with the hydroxilic end groups of the perfluoropolyether-diols, and then in extracting selectively the monofunctional species from the difunctional species by using solvents of different polarity (CFC 113 and methanol).

Process flow diagram is reported in fig. 4. The stirred batch reactor, heated by an external heating circuit, is fed with silica gel, CFC 113/MeOH and the PFPE mixture. After three hours of stirring the perfluoropolyether-diols are adsorbed on the silica gel by distilling the solvents, which are recycled for further purification. The reactor is then fed with CFC 113, and the obtained slurry is stirred for three hours and transferred into a pressure filter. The clear solution is charged into a different stirred vessel where the process agent, CFC 113, is distilled from the low functional PFPE and recycled, while the residue is fed into the first reactor and suspended in methanol at 50°C. The mass is cooled at room temperature and transferred into a pressure filter. Silica gel is recovered and recycled. The high functional perfluoropolyether-diols are obtained from the clear solution by evaporating the methanol in the second vessel.

### **Reason why it is needed**

CFC 113 is used in this purification because:

- it is the only known process agent able to dissolve both the perfluoropolyether mixture and the methanol in the preparation of the stationary phase;
- its polarity is such that it extracts from the stationary phase only the species with low functionality.

### **Quantity used**

2 t was used in 1997

A consumption of 15 t is expected in year 2000.

Emissions

Emissions are practically zero. CFC 113 is separated from the perfluoropolyethers by distillation and recycled. Off gases are conveyed to a specially designed unit where they react with water at very high temperature and are fully converted to CO<sub>2</sub>, HF and HCl. Total (organic and inorganic) fluorine emission allowed from this unit by local authorities amounts to less than one gram per hour (< 1 g/h)

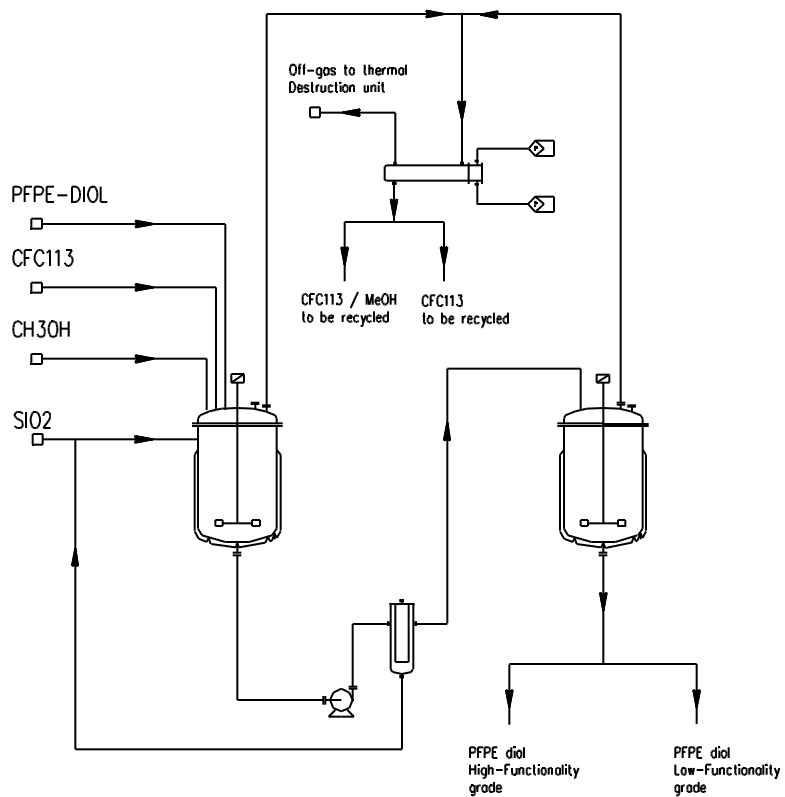

Fig. 4: High functionality PFPE diols process